

SYSTEMS AND EQUIPMENT FOR SPACE HEATING

P. Koronakis

Department of Mechanical Engineering, T.E.I. of Piraeus, GREECE

Keywords: Modern-ancient space heating systems, energy sources, energy savings, insulation, geothermal heat pumps, active-passive solar systems, direct-indirect gain solar systems, heat recovery

Contents

1. Introduction
 2. Heating devices and systems, a short historical follow up
 - 2.1 Fireplaces
 - 2.2 Local Space Heaters
 3. Energy sources for space heating
 - 3.1 Fossil Fuels
 - 3.2 Electricity
 - 3.3 Geothermal Energy
 - 3.4 Hybrid Energy Sources
 - 3.5 Solar Energy
 4. Thermal insulation, a must in energy savings
 - 4.1 Insulation Materials
 - 4.2 Energy Savings
 5. Conventional space heating systems and design considerations
 - 5.1 Central Space Heating Equipment
 - 5.2 Design Considerations
 6. Instruments and control devices usually found in space heating systems
 - 6.1 Adjustments made on Heat Production Components
 - 6.2 Heat Distribution Components
 7. Passive and active solar space heating systems, solar energy collection and storage
 - 7.1 Active Solar Space Heating Systems
 - 7.2 Passive Solar Space Heating Systems
 - 7.2.1 Direct Gain Systems
 - 7.2.2 Indirect Gain Systems
 - 7.2.3 Sunspaces, Solar Greenhouses
 8. Geothermal energy utilization space heating systems
 9. Some simple heat-recovery energy-saving systems
- Glossary
Bibliography
Biographical Sketch

Summary

The design of a space heating installation system indicates the progress being made in the field. It reflects the level of implementation of new ideas by local societies as well as the energy policy at the National level.

The use of sophisticated equipment and apparatus for the operation and control of modern space heating systems require reliable technical services and experienced personnel. In addition, final users (homeowners) should know the fundamentals, or be informed of the basic layout procedure, regarding implementation of different space heating systems in order for them to be in the position to judge and use them properly.

Incorporation of sustainable energy sources in space heating systems should be evaluated not only in terms of the initial cost of the investment, but also with respect to the annual energy savings, and the environmental impact.

Out of all currently known and available energy sources, solar energy is the only sustainable form of energy that could be collected directly or indirectly, and used as heat inside a building. In most areas of the world, solar irradiance irradiates walls and roofs of buildings in quantities that surpass the corresponding heating requirements, on an annual basis. So, it is up to the building owners and the designers of space heating systems to come up, in mutual agreement, with the most suitable solution

Initially, this chapter tries to give a short historical background of the space heating systems and devices used at different eras, keeping in mind that man's effort for accomplishment and maintenance of indoor thermal comfort has been a widespread practice for ages. Earth's known energy sources and currently available energy forms are considered next, just before the article looking at energy savings when considering thermal insulation. Next in text come the conventional space heating systems and the proper design considerations, followed by space heating control systems and devices. Most attention is paid on the next entity presenting operation and layout of active and passive solar space heating systems and techniques. Utilization of geothermal energy through the use of earth pipes or other hybrid techniques is presented next. Finally, a few examples of heat recovery and energy saving simple systems are shown schematically.

1. Introduction

Space heating is generally understood to mean the heating process of internal spaces and premises. It could apply to residential, office, commercial, and industrial buildings, animal raising units, greenhouses, etc. This heating process is accomplished by means of a *space heating system*, meaning the medium and the type of apparatus used to transfer heat from the medium to the enclosure to be heated.

Space heating systems are either *local*, if heat from a heating appliance is delivered directly into the heated room, or *central*, when heat generated at a center heats up the medium which in turn delivers its thermal load to the heated space. Space heating systems supply thermal energy to an enclosure to replenish heat losses that occur whenever the inside temperature is, higher than the prevailing outside one, but lower than a set value, i.e. 20°C. Heat losses from a building include heat transmitted through the building's structural shell, whose heat is eventually lost by convection, and thermal emission (radiation) from the external surfaces, and heat lost by air infiltration and/or mechanical ventilation.

The ideal heating system works with high efficiency supplying only the amount of heat

that is necessary to maintain internal conditions at a level providing thermal comfort to the room occupants. Besides clothing, the main parameters affecting thermal comfort include, air temperature, air moisture content, air speed and quality, and mean radiant wall temperature. Space heating is responsible for conditioning the air temperature, and the mean radiant wall temperature of internal surfaces surrounding the enclosure. Both of these temperatures, equally weighted, form the *indoor (or sensible) room temperature*, a value which for thermal comfort should be kept as uniform as possible along any horizontal, or vertical direction throughout the heated space.

2. Heating Devices and Systems, a Short Historical Follow Up

Slaves' tears and sweat, live testaments to the ancient mechanic, still echo their suffocating cries in the ruins of sophisticated heating systems seen in dug-out bath houses and palaces that once thrived in ancient Rome. Today, solar and conventional fully automatic furnaces and boilers burning gas, oil, coal, or electricity are widely used to heat up a medium fluid which in turn is sent to deliver its heat to the heated space. But the way and means that humans used to keep themselves warm, from the prehistoric times till today, have followed an evolutionary path, at each step, reflecting the level of civilization and technology achieved.

Heating systems have changed greatly over the years. Early humans used open pit fires in their home-caves. These cave dwellers felt the need for heating because their caves became and remained cold for long periods of time, particularly during and after cold winters.

Later humans, in some places, relied on fermenting manure and/or animals for warmth. The main disadvantage of the open fire was the production of vast amounts of smoke that in a closed space would create problems. This problem was solved when the Romans discovered the *charcoal* that burns on metal plates without the production of smoke.

Some of the earliest recorded heating systems were built by the Romans, while the Chinese first used stoves around 600 BC. Remnants of a Roman central heating system (as seen i.e. in the baths of *Caracalla*, Rome, 211-217 AD) known as *the Roman Hypocaust (balneae pensiles*, invented by *Sergius Orata* in the 80 BC) shows ducts constructed underneath the heavy built floor where hot air and/or flues were passed through guided up the duct work inside the walls and through side vents out to the environment, as it can be seen in Figure 1.

In this way heat was perceived to come from all surfaces surrounding the closed room uniformly. Heat was produced by burning wood or charcoal at a lower than the floor level. Attendants working in the ancient Roman baths kept the temperature of floors, walls and water inside the *tepidarium* (a trapezoidal room), and the *caldarium* (a rectangular room with niches in the corners) at a desirable level through the addition of new wood or charcoal to the fire. Both of these rooms were built with raised floors and hollow walls.

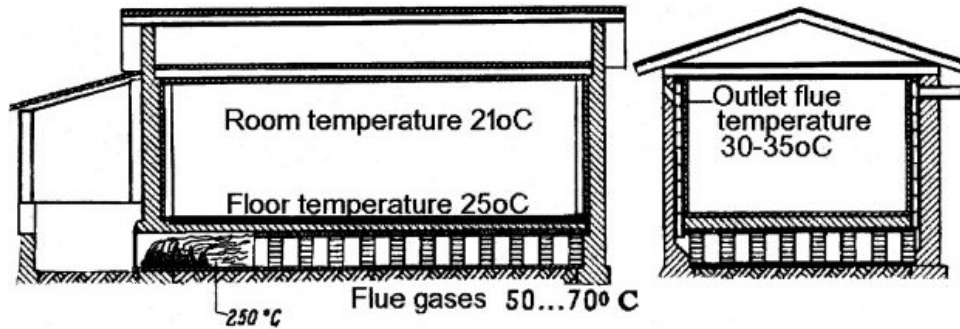

Figure 1: The ancient Roman Hypocaust

About the same time, the Koreans developed and used in their homes the *Odol* duct system. This was a system of ducts running parallel underneath the floor, constituting an integral part of the smoke chimney, where flues were passed through and up a chimney stack at the other end of the house. In this way, the entire floor was heated from the heat generated in a stove located lower than the floor level. Variations of the same principle and technique can be seen in other parts of the world as is the Chinese *K'ang*, the Afghan *Tawakhaneh*, the German *Steinofen*, etc. The German *Steinluftheizung*, first seen in the 12th century, is a type of central space heating system where layers of stones were heated by burning wood in an enclosure, i.e. placed at the basement. After the fire had died out, the heat accumulated in the stones was transferred to the air which slowly moved up the chimney by gravity entering into the house through floor vents which were kept close when the fire was burning.

2.1 Fireplaces

Fireplaces are local space heating systems having the open pit fires as ancestors. One can find fireplaces in buildings all over the world, particularly in places experiencing mild or moderate winters. The use of fireplaces in the form of round pit center room fires is known from prehistoric times. The oldest remnants of such round pit fires, placed at the center of the most significant room, can be seen in the palace of the city of Mycenae in ancient Greece. This central fireplace, which also stands for the family altar, is located directly below an opening on the inclined ceiling looking up at the sky. Fireplaces in their common appearance are first seen much later, specifically, at the beginning of the 9th century, while improvements continued up to and through the 12th century. Their use spread out fast after the 13th century when the chimney was first introduced.

Conventional fireplaces may look warm and cozy, but they tend to be relatively inefficient since they heat up places mainly by the radiant heat escaping from the front aperture facing inside. Some basic rules for the sound operation of a fireplace are the following:

- The cross sectional area of the chimney must be at least equal to (actually, a little more than the) 1/10 of the area of the base surface of the fireplace
- The surface area of the fireplace base where the fire seats, expressed in m^2 , must be equal to the 2-4% of the number of m^3 expressing the volume of the room to be heated
- The back wall surface of a fireplace must end up upwards inclined forward and

forming a Venturi neck, while the rear wall behind the fireplace's back wall must continue its way up reaching the far down end of the chimney's back wall behind the Venturi neck. In this way, the V-shaped space formed behind the Venturi neck will divert upwards the flow of the cooled smoke that had followed down the chimney's rear wall surface. So, the diverted cooled smoke rising up will mix with the fast rising hot flue gases that have passed through the Venturi moving up the chimney.



Figure 2: An open type conventional fireplace

Thermal efficiency of conventional type fireplaces, as e.g. the one shown in Figure 2, usually remains around 10%, although negative efficiency values have been measured at some cases during cold blizzards. The thermal power delivered to room by a fireplace may vary from 3.5 kW m^{-2} to 4.5 kW m^{-2} of front aperture area. Classic fireplaces suck the warm room air that is vented up the chimney; then the low pressure created inside the room pulls the cold outside air into the house through cracks and openings around windows and doors. Modern design fireplaces have much improved thermal efficiency that quite often may measure up to 55%. This is accomplished by adding to the classic fireplace a number of energy saving improvements and mechanisms. The following are some rules to improve the efficiency of a classic design fireplace:

- Install a damper to regulate the room draft by closing off the chimney when the fireplace is not functioning.
- Draw outside air by ducting it directly beneath the fire. In this way the fire does not consume for combustion the warm room air.
- Circulate room air around the firebox through self contained ducts located behind the fire place by sucking cool room air through lower vents and releasing it warm back into the room from openings near the top of the fireplace.
- Install heat-resistant glass-doors and secure completely the fireplace front-entrance. In this way, no room air is permitted to escape up the chimney.
- Place inside the fireplace a small air-to-water heat exchanger made out of a number of heat resistant pipes bent into shape that fit around the firebox. The low temperature water helped by a circulator pump enters at the bottom, is heated up

by the fire, and then runs out warm at the top.

2.2 Local Space Heaters

Stoves are enclosed devices used for local space heating and/or cooking, burning any fossil fuel. The oldest known stoves are the cylindrical metal pots used in ancient Egypt and Greece. At these early times, the produced smoke was first let free into the room, and then it was either helped to escape naturally through room openings, or guided outside through a hole in the roof. Iron stoves are known to exist since the 15th century, while the first manufactured cast iron stove is dated back to the 17th century.

Benjamin Franklin improved the iron stove by adding sliding doors to control the flow of air through the combustion chamber. Modern iron and cast iron wood and coal burning stoves have improved thermal efficiency that can measure up to 65-75% (for wood stoves with catalyst), flue gas temperature ranging from 250 °C to 300 °C, body surface temperature from 200 °C to 250 °C, and heat emission ability of 2-6 kW m⁻² of body surface area.

Today, there are a large number of stoves using different energy sources. Oil, gas, kerosene, and electric local heaters are manufactured satisfying modern safety standards. In addition, electric heat pumps all-year-around air conditioning units, though more efficient than simple electric heaters, have gained the preference of hundreds of thousands of end-users in the developed and developing countries. This sudden energy demand has extremely increased the burden on power companies that seem unable to cover peak load demand at national level, and local level as well.

3. Energy Sources for Space Heating

3.1. Fossil Fuels

Nearly all energy used for space heating is stored solar energy. Wood, coal, oil, gas, wind-power, hydropower, wave-power, crop raising for fuel, solar heating could not exist without the sun. When gaseous, solid, or liquid fuels burn, they give off energy. The energy contained within the fuel is changed mainly into heat, which is known as *the calorific value* of the fuel. The calorific values of some common fuels are:

Anthracite 37 MJ kg ⁻¹	Wood 18.5-20 MJ kg ⁻¹	Lignite 20-25 MJ kg ⁻¹
Coke 31-33 MJ kg ⁻¹	Oil 42-45 MJ per liter	Paraffin 38 MJ per liter,
Natural Gas 32-35 MJ m ⁻³ at normal pressure and 20°C		
Hydro Gas (old-fashioned domestic gas) 17 MJ m ⁻³ at normal pressure and 20°C		
Propane Gas 92 MJ m ⁻³ at normal pressure and 20°C		
Butane Gas about 120 MJ m ⁻³ at normal pressure and 20°C		

Wood but mainly coal-fired *furnaces* (air heaters) and *boilers* (water, or steam heating devices) were in use in the developed countries up to and through the 1950's when the clean air issue became important. Another reason for putting away wood and coal is the lower thermal efficiencies the large size of fireboxes burning these two fuels as compared to modern compact highly efficient oil, or gas furnaces and boilers. Space heating

systems using liquid, solid or gaseous fuels need a chimney to get rid of the combustion products. Thus chimneys, in addition to the contamination of the atmospheric air with CO₂ and other constituents, are a source of heat added to the environment, something that electrical and other more “noble” heating systems have the merit not to.

3.2 Electricity

Generation of electricity in a central thermal power station is an inefficient procedure from the point of view of making use of the calorific value of the fossil fuel. Even the most modern power stations are only about 35% efficient in converting fuel energy into electricity, while older power stations are even worse. On the average, only 28% of the fuel’s energy is converted into electricity; the rest of the produced heat is either totally blown off into the atmosphere via the cooling towers, or have part of this value recovered and used for space heating in district heating plants.

The positive side is that thermal power plants can burn the kind of fuel that is difficult to be used at home. Thus, fine coal or lignite powder with up to 40% ash, treacle thick fuel oil can be utilized by power stations. It is also positive the fact that electricity can be converted into heat at 100% efficiency. This means that in the case of electric heating the cost of one unit of electric heat is exactly the same as the cost of one unit of useful heat. In countries where electricity is cheap, space heating is provided by laminated electric panels embedded or mounted on ceilings, walls, floors, or by electric furnaces or boilers as central heating units

3.3 Geothermal Energy

Geothermal energy is the heat contained within the Earth that can be recovered and put to useful work or heat for residential, commercial, industrial and power production uses. Within the ground there exists a continuous and steady flow of heat, the terrestrial heat flux, directed upwards which is characterized by the geothermal temperature gradient of the region, in other words the increase in temperature per unit of depth as one moves into the Earth’s crust. Normally, this temperature gradient value is close to 0.3 °C m⁻¹, except in and around active volcanic regions where larger values are accounted.

Geothermal resources constitute of inexhaustible terrestrial heat reservoirs spread around the world in countries with active plate margins where rocks heated by magmas deliver their heat, at high to moderate temperatures, to properly design fluid systems which in turn deliver it to the earth’s surface. In addition, there are other equally important geothermal resources, but at lower temperatures, which they are widespread throughout the world deriving their heat from the normal terrestrial heat flux.

Low to moderate temperature (20°C to 140°C) geothermal fields are quite abundant around the world and are used to provide heat for homes, fisheries, greenhouses and industry. High temperature (greater than 140°C) geothermal resources are used in power stations to run steam turbines. At present, the main efforts are focused on the utilization of high to moderate temperature geothermal resources, about 60% of which occur in developing countries.

3.4 Hybrid Energy Sources

Another way to heat up an enclosure is through the use of an electromechanical or thermo-mechanical device known as *heat pump*. With a heat pump, as the word says, heat is “pumped” away from a low temperature region (the heat reservoir) to a place of higher temperature (the heated space). For this to be achieved, work must be offered to the system, but the amount of energy transferred as heat is greater than the equivalent amount of the work spent during the process, with the work amount expressed in energy units.

As a matter of fact, the theoretical total amount of heat energy delivered to the higher temperature region is equal to the sum of the heat energy pumped plus the amount of the energy spent as work. Looking up more closely a heat pump behaves like a refrigerator mechanism. The only difference is that for a heat pump it is the heat released at the condenser that is used, instead of the heat absorbed at the evaporator as it is in the case of a cooling device.

In heat pumps as well as in freezers, the work done by a motor is used in the compressor unit. Compressor units are usually run by electric motors, but when run by an internal combustion engine, the thermal performance of the heat pump used for heating could be greatly improved by using the heat present in the exhaust gases as a heat source.

In general, heat pumps are considered as energy saving devices. In the case of geo-thermal, or solar assisted heat pumps they have their evaporator unit buried into the earth, or receiving heat from the hot solar collector fluid. So, when heat pumps are used for heating, they are pumping heat off the relatively high temperature reservoir (higher than the ambient temperature) of the geothermal field, or solar collector fluid.

-
-
-

TO ACCESS ALL THE 36 PAGES OF THIS CHAPTER,
Visit: <http://www.eolss.net/Eolss-sampleAllChapter.aspx>

Bibliography

Allred J.W., Shinn J.M., jr., Kirby C.E., and Barringer S.R. (1976). An inexpensive economical solar heating systems for homes. NASA Report TMX-3294, U.S. Department of Commerce, National Technical Information Service. [This Report describes a low-cost solar home heating system to supplement an already installed warm-air heating system].

Antonopoulos K.A., and Koronaki E. (1998). Apparent and effective thermal capacitance of buildings. *Energy* **23**, 183-191. [This paper gives the effective thermal storage capacity of buildings calculated for various characteristic cases.]

Carriere D., and Day F. (1980). SOLAR HOUSES FOR A COLD CLIMATE. John Wiley & Sons, Toronto, CANADA. [The central theme of this book is the presentation of 26 solar heated houses in cold climates with strong emphasis placed upon energy conservation schemes.]

Dimoudi A., Panno G., Santamouris M., Sciuto S., and Argiriou A. (1996). DESIGN SOURCE BOOK ON PASSIVE ARCHITECTURE. CIENE, Athens, GREECE. [This book provides information regarding energy conservation in buildings by giving the main issues of passive solar architecture.]

Fanger P.O. (1973). Thermal Comfort Analysis and Applications in Environmental Engineering. McGraw-Hill, USA. [The PMV thermal comfort index that holds for typical winter and summer indoor conditions and normal human activities is the main issue in this work.]

IEA/OECD (1986). ENERGY FOR BUILDINGS, Microprocessor Technology. Paris, FRANCE. [This book provides guidelines on building energy management and control systems for new and retrofit applications.]

Jordan R.C., and Liu B.Y.H. editors. Applications of Solar Energy for Heating and Cooling of Buildings. ASHRAE GRP 170. [A number of works by different authors on solar system components are presented regarding water heating, as well as, space heating & cooling.]

Kreider J.F., and Kreith F. (1975). SOLAR HEATING AND COOLING: Engineering, Practical Design, and Economics. McGraw-Hill, USA. [This is a practical book giving details on how to design solar energy systems for buildings.]

Recknagel & Sprenger E. (1977). Taschenbuch für Heizung und Klimatechnik, **vol. 1** Heizung. (in German) Berlin, GERMANY. [This book includes quite a few details regarding the design and installation of heating systems.]

Rigas K. and Koronakis P. (1995). Measurements of solar irradiance on the horizontal and vertical plane in Athens. *Technika Chronika*, Scientific Journal of the Technical Chamber of Greece **15**, 29-40, (in Greek). [This work presents hourly values of processed solar irradiance measurements logged over a two and a half year period in Athens, Greece. It refers to global solar irradiance falling on a vertical plane facing due South, West, North, and East, as well as, global and diffuse solar irradiance received on the horizontal].

Summer J.A. (1975). DOMESTIC HEAT PUMPS. Prism press, Dorchester, UK. [It is a book on heat pumps presented as the means for reducing heating energy consumption in buildings.]

Szokolay S.V. (1975). Solar Energy and Building. The Architectural Press, London, UK. [This book presents some very useful information on the implementation of solar systems for the space heating of buildings.]

Biographical Sketch

Pericles-Nicholas KORONAKIS, born on May 17, 1945 at the island of Zakynthos in Greece, married, two daughters, mechanical engineer, professor at the Department of Mechanical Engineering, TEI of Piraeus, Greece.

He studied in the USA at the U. Ill. Chgo. C., where he obtained a BSc(hon) Degree in Aerospace Sciences (scholar. 1965-1968), a MSc(hon) Degree in Energy Engring. (1970), and a PhD in Fluid and Solid Mechanics (Fellow 1968-73).

Speaks, reads, and writes Greek, English. Reads and understands fairly French and Russian.

Coll. Instr. YMCA C.C., Chgo. (1968-1970), sr. instr. YMCA C.C., Chgo. (1970-1973), lectr. U. Ill., Chgo. (1973). Military service, released 2nd Lt. Hellenic Army Corps Engrs. (1974-75). Assoc. prof. KATEE of Piraeus (1976-78). Prof. TEI of Pireaus (1978-). Head of Fluid Mechanics Lab, Dept. Mech. Engring. TEI of Piraeus (1978-). UNESCO Fellow (1981). Lectr. Hellenic Air Force Acad. (1982-84).

Author: (six books), Fluid Mechanics, Applied Fluid Mechanics, Experimental Fluid Mechanics (I and II), Fluid Mechanics Problems (I and II).

Author: (a large number of class notes) for undergraduate student courses, and graduates attending seminars regarding, Aerodynamics, Thermodynamics, passive and active solar energy systems, proper building design studies and energy savings, renewable energy systems, simplified design tools and dynamic design tools for the thermal simulation of buildings.

Author: (twenty two research studies and papers presented at conferences) on building design studies and energy savings.

Author: (nine publications) on solar irradiance, renewable energies, atmospheric pollutant emissions.

Participated or headed six research projects on proper building design and energy savings topics.

Operates since 1991, a fully automated (unattended) solar irradiance (including UV-global) measuring station at the TEI of Piraeus campus site.

Reviewer: Solar Energy Journal (former), Journal of the Air & Waste Management Association

UNESCO – EOLSS
SAMPLE CHAPTERS