

RELAY AUTOTUNING OF PID CONTROLLERS

D. P. Atherton

University of Sussex, UK

Keywords: PID controller, autotuning, limit cycle, sinusoidal describing function, critical point, gain margin

Contents

1. Introduction
 2. Relay Autotuning
 3. Analysis of Relay Autotuning using the DF method
 4. Controller Design Based on the Critical Point
 5. Further Considerations
 6. Conclusions
- Glossary
Bibliography
Biographical Sketch

Summary

This section is concerned with the relay autotuning method for setting the parameters of a fixed form controller, usually a PID controller. It is first explained how the method is an extension of a concept first discussed by Ziegler and Nichols for setting PID controller parameters based on an estimate of the gain margin, or process critical point.

The theoretical approaches to analyzing the limit cycle obtained in an autotuning experiment are explained. The merits and some problems of using the describing function method of analysis for estimating the critical point are discussed.

Setting of the PID controller parameters based on the critical point information is then covered and an example given. Finally a few further points are mentioned regarding practical aspects of PID control.

1. Introduction

The classical approach to the design of control systems is to use a mathematical model, typically in transfer function or state space form, of the process to be controlled. This model is usually obtained either from the physical equations of the process or by identification, namely an experiment to obtain process input and output operating data which is then analyzed to find a mathematical model. Whichever of these approaches is used it may take a considerable amount of time.

One is thus led to asking whether satisfactory control can be achieved by adjusting the parameters of a fixed controller, such as a phase lead or PID, based on less information, obtained 'in situ', than a detailed mathematical model. This is particularly relevant too if the parameters of the model change slowly with time.

Gain and phase margins have been used for many years as indicators of stability and performance and these show how near the plant frequency response, assuming a reasonably smooth characteristic, is to the critical point $(-1, j0)$.

Ziegler and Nichols, Z-N, realized that if the gain margin could be estimated quickly, then it should be possible to find good controller settings for many practical situations from this information. They therefore suggested that one possible way to do this in practice would be by setting a PID controller into the P mode and adjusting the gain until an oscillation took place.

The value of the controller gain, K , and the oscillation frequency, ω , would then be measured. It should be remembered that at the time of this work nearly all PID controllers were pneumatic so that only simple changes could be made. Assuming a linear plant model then theory shows that the frequency of oscillation is, ω_c , where the Nyquist plot of the plant frequency response has a phase shift of -180° and the gain margin is $1/K$ expressed in dB.

Denoting this K by K_c , then K_c and ω_c are referred to as the critical or ultimate gain and frequency. The second contribution of Z-N was to suggest how the PID controller parameters could be selected based on the measured values of K_c and ω_c , and more will be said on this topic later.

From a practical point of view, although it has been used appreciably in industry, there are difficulties in performing the test. Even if the plant behaves as a linear model if the gain is too low no oscillation appears. If it is too high the oscillation amplitude builds up and is only limited by saturation occurring at some point in the system. For a slow response process, typical of many process control plants, there is also a considerable delay in the oscillation amplitude change, assuming the gain is high enough, in responding to a change in gain.

Add to this the fact that the plant will probably not behave linearly due to dead zone, friction or other nonlinear effects and the difficulties and possible dangers created by trying to set up uncontrolled oscillations, the practical problems of this technique can be appreciated. Further any measurements will be made on noisy signals.

Hägglund and Åström therefore suggested a modification in the testing procedure, which became easily implementable with the advent of microprocessor controllers, of replacing the P mode by a relay. This typically results in a nonlinear, here used in the sense of a non sinusoidal waveform, oscillation, known as a limit cycle, in the loop. This approach has become known as relay autotuning. It is the topic of this section, which involves showing how the limit cycle information can be used to set the controller parameters.

Today microprocessor controllers can be programmed to perform tasks additional to the 'standard one' of implementing a control algorithm. These include, for example, fault diagnosis and autotuning. In a general sense autotuning can be defined as a procedure

performed by a controller in order to decide upon appropriate settings for its parameters, so many approaches are clearly possible.

For example, for fast systems such as motor speed control, it may be possible if the load or other parameters vary slowly with time, for the controller to periodically do step response tests for different controller parameters and use this information to readjust its parameters. Autotuning procedures depend in practice on what is permissible in terms of the time allowed, the effect on the process operation and safety considerations. Indeed some relay autotuners estimate the required information for controller tuning from less than the full period of the limit cycle.

2. Relay Autotuning

Consider the simple feedback system shown in Figure 1, where for the estimation mode the controller is replaced by an ideal relay. Under certain conditions, which are not precisely definable but can be ascertained approximately by several methods, the closed loop will possess a limit cycle.

The simplest case, which is considered here, is when this limit cycle is a symmetrical square wave at the relay output. Whether this is the case depends upon the d.c loop conditions, which in turn depend upon bias input signals and the location of integrators in the loop. It is then possible to obtain information about the process from this limit cycle using one of two analytical approaches.

The first is to use the approximate describing function (DF) method of analysis and possible extensions taking into account higher harmonics. The second to use one of the exact methods for finding limit cycles in relay feedback systems, all of which are equivalent, such as that due to Tsytkin.

The DF method can be used either to estimate the critical gain and frequency, or if a transfer function model is assumed for the plant, two of its parameters, assuming any others are known, can be estimated. If higher harmonics are taken into account further extensions are possible.

Since the DF method is approximate, as it assumes that the limit cycle at the relay input is sinusoidal, as discussed in the next section, it has to be used with ‘understanding’. For example, if it is used when the limit cycle at the relay input is distorted for the estimating plant parameters approach, the solution of the two nonlinear algebraic equations may produce unrealistic solutions.

Application of the Tsytkin method, which requires a plant transfer function to be assumed, again yields two nonlinear algebraic equations, which assuming perfect measurements of the peak amplitude and frequency of the limit cycle yield exact values for two unknown plant parameters.

Many extensions to both these methods for estimating plant parameters from limit cycle data can be found in the literature. For example, if the limit cycle is not odd symmetric,

which may be achieved by adding a bias signal to the loop, then four nonlinear algebraic equations can be found which in principle allow solution for four parameters.

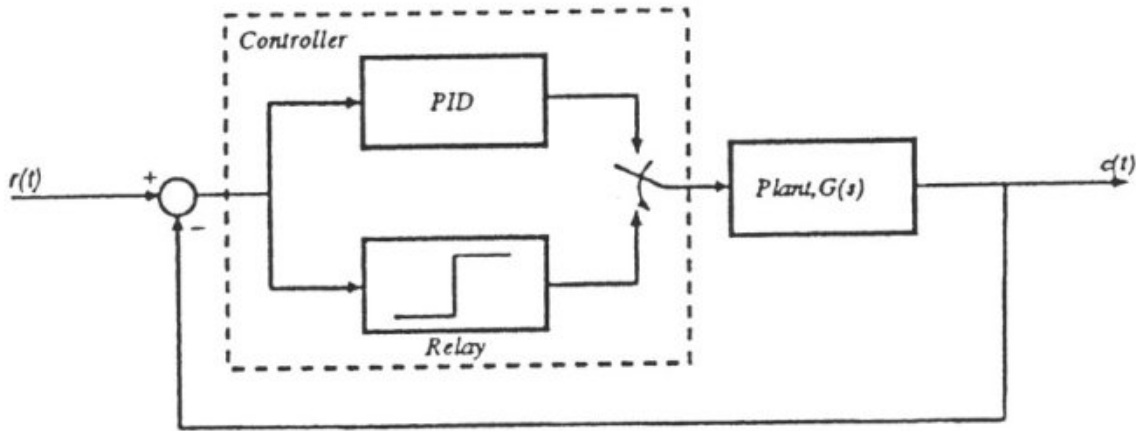

Figure 1 Block diagram of autotuning scheme.

There are a few disadvantages with the parameter estimation approaches which are:-

- (i) the possible requirement to have the controller 'measure' several limit cycle parameters,
- (ii) the need to embed in the controller both a nonlinear algebraic equation solver to find the plant parameters from the measurements, and an algorithm which uses these to find suitable controller parameters,
- (iii) the difficulty of getting accurate measurements from noisy signals. This can be improved by averaging over several periods of the limit cycle but in turn takes additional time.
- (iv) the plant may be nonlinear and a linear model not be easy to justify.

There are some advantages to the approach of estimating the critical point using the DF method. These include:-

- (i) The expressions to estimate K_c and ω_c from the two measurements of limit cycle amplitude and frequency are simple.
- (ii) Reasonable estimates can sometimes be obtained in less than one period of the limit cycle.
- (iii) If time allows K_c and ω_c can be measured for different operating conditions and different limit cycle amplitudes, since this can be controlled by the relay height. These measurements can reveal aspects of nonlinear plant behavior and can be used for scheduling controller parameters.
- (iv) The final setting of the controller parameters is often not very critical. The desired settings normally relate to economic operation which is often difficult to compare precisely with, say, a 20% change in overshoot or settling time for a step set point input or disturbance response. If there are critical situations, for example, a step set point response should never have an overshoot greater than 5%, then a combination of conservative parameter

settings, yielding a slower response and longer settling time together with, perhaps rule based, safety procedures can solve the problem.

In the next section we therefore discuss in detail only the relay autotuning method and determination of the critical point using DF analysis.

-
-
-

TO ACCESS ALL THE 11 PAGES OF THIS CHAPTER,
[Click here](#)

Bibliography

- Åström, K J and Hägglund, T. (1984). Automatic Tuning of Simple Regulators with Specifications on Phase and Amplitude Margins. *Automatica*, 20, pp 645-651. [The first paper to suggest using a relay to replace the proportional gain in the Ziegler Nichols loop cycling method. The advent of microprocessor controllers made the approach practical. Limit cycle result obtained using the known describing function method.]
- Åström, K J. (1996) Tuning and Adaptation, Plenary Lecture, *IFAC Congress*, San Francisco, USA. [An interesting paper showing further aspects of tuning which can be found using relay induced limit cycles.]
- Atherton, D P. (1975). *Nonlinear Control Engineering: Describing Function Analysis and Design*. Van Nostrand Reinhold. [A book with probably the most detailed coverage of classical approaches for nonlinear control systems, with major concentration on describing function methods.]
- Atherton D P, Benouarets M and Nanka-Bruce O. (1993). Design of Nonlinear PID Controllers for Nonlinear Plants. *Proceedings, IFAC World Congress*, Sydney, Australia, 3, pp 355-358. [Presents an approach to implementing nonlinear PID controllers based on relay autotuning tests.]
- Atherton, D P. (1997). Improving the Accuracy of Autotuning Parameter Estimates. *Proceedings, IEEE International Conference on Control Applications*, Hartford, USA, pp 51-56. [Shows how simple corrections can be made based on the limit cycle waveform to get better estimates of the critical point from relay autotuning.]
- Kaya, I and Atherton, D P. (1999). Using Limit Cycle Data for Parameter Estimation. *Transactions of the InstMC*, 21, pp 21-29. [Uses exact analysis for limit cycles in relay systems with plant transfer functions of known form to show how the plant parameters can be estimated from simple measurements on the limit cycle.]
- Luyben, W L. (2001) Getting More Information from Relay Feedback Tests. *Ind. Eng. Chem. Res.* 40, pp. 4391-4402. [A paper giving information on other loop properties which can be obtained from relay tests.]
- Majhi, S and Atherton, D P. (2000) On-Line Tuning of Controllers for An Unstable FOPDT Process. *IEE Proceedings Control Theory and Applications*, 147, pp. 421-427. [Discusses the application of autotuning to tune PID parameters for the control of an unstable FOPDT plant.]
- Tsympkin, Y Z. (1984). *Relay Control Systems*. Cambridge University Press. [The English translation of a classical work on limit cycles in relay systems earlier published in the USSR.]

Yu, Cheng-Ching. (1999). *Autotuning of PID Controllers*. London, Springer-Verlag [A book devoted entirely to relay autotuning. [Has some good material but has deficiencies regarding relay produced limit cycles compared with specialist works on the topic.]

Ziegler, J G and Nichols, N B. (1942). Optimum Settings for Automatic Controllers. *Trans ASME*, 64, pp 759-768 . [The original paper suggesting how the parameters of PID controllers might be chosen based on one of two simple tests. The first using an open loop plant step response, the second using a closed loop test with proportional control and the gain adjusted to produce oscillations.]

Zhuang M and Atherton D P. (1993). Automatic Tuning of Optimum PID Controllers. *IEE Proceedings, Control Theory and Applications*, 140, pp 216-224 [Presents results showing how PID controller parameters can be chosen to satisfy integral performance step response criteria based on knowledge of the plant critical point.]

Biographical Sketch

Derek Atherton was born in Bradford, England on 21 April 1934. He has a B. Eng from Sheffield University and PhD and D.Sc. from Manchester University. He taught at Manchester University, and McMaster University and the University of New Brunswick in Canada before taking up the appointment of Professor of Control Engineering at the University of Sussex in 1980, where he currently has a part-time appointment. He has served on committees of the Science and Engineering Research Council, as President of the Institute of Measurement and Control in 1990 and President of the Control Systems Society of the Institute of Electrical and Electronic Engineers, USA in 1995, and also served for six years on the International Federation of Automatic Control (IFAC) Council. His major research interests are in nonlinear control theory, computer aided control system design, simulation and target tracking. He has written three books, one of which is jointly authored, and published over 300 papers.